



**ULTIMATRON
FRANCE**

**5 YEARS
WARRANTY**

Technical sheet

ULTIMATRON LiFePO4 Smart BMS RV Underseat Lithium Battery
ULM-12-180

Compared with traditional batteries, our lithium iron phosphate batteries (LiFePO4) have many advantages:

- 5 years manufacturer's warranty
- The safest technology, without risk of fire or explosion
- Long service life
- Constantly improving storage capacity
- High stability even under extreme loads
- No memory effect, no need for full charge and discharge cycles
- High performance even under extreme conditions
- Deep and regular discharge and charging efficiency
- Small size and light weight

Integrated Battery Management System (BMS)

To allow the control and the charge of the different elements of an accumulator battery and to protect it against overcharging, overvoltages and overheating.



Note: Series and parallel connection for 12V, 24V, 36V, 48V applications.

Integrated Bluetooth 4.0 monitoring



You have all important battery data always on your smartphone or tablet. The application displays the data in real time.





**ULTIMATRON
FRANCE**

TECHNICAL SHEET

ULM SMART BMS SERIE 12.8V

ULTIMATRON LiFePO4 Smart BMS RV Underseat Lithium Battery ULM-12-180

ELECTRICAL PERFORMANCE

Nominal Voltage	12.8V
Nominal Capacity	180Ah
Capacity @ 36A	300min
Energy	2304Wh
Resistance	≤15mΩ @ 50% SOC
Self Discharge	<3% / Month
Number of Cycles	>6000@80%D.o.D

CHARGE PERFORMANCE

Recommended Charge Current	50A
Maximum Charge Current	90A
Recommended Charge Voltage	14.6V
Charge Cut-Off Voltage	14.6V (2000ms)
Reconnect Voltage	≤13.8V
Balancing Voltage	>12.8V

DISCHARGE PERFORMANCE

Maximum continuous Discharge Current	150A
Peak Discharge Cut-Off Current	450A (200~500ms)
Discharge Cut-Off Voltage	10V (2000 ms)
Reconnect Voltage	>11.2V
Short Circuit Protection	1000-2000A ± 400A (200 ~ 800 μs)

TEMPERATURE PERFORMANCE

Discharge Temperature	-20 ~ 75 °C
Charge Temperature	0 ~ 50 °C
Storage Temperature	-5 ~ 35 °C

DIMENSION

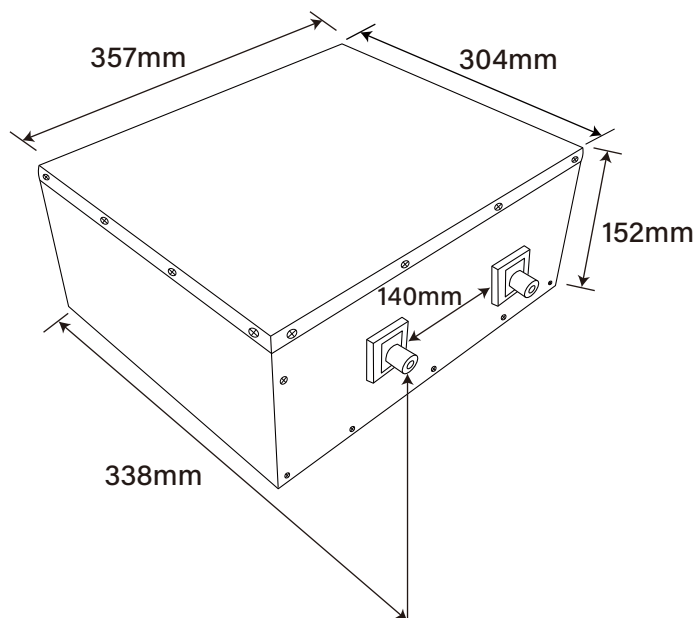

Dimension L357 * W338 * H152 mm

MECHANICAL PERFORMANCE

Weight	23.7 kg
Terminal Type	M8
Terminal Torque	80 ~ 100 in-lbs (9 ~ 11 N-m)
Case Material	Metal
Ingress Protection Code	IP65
Bluetooth	Bluetooth 4.0 with smartphone app

COMPLIANCE

Certifications	CE UN38.3 UL1642 & IEC62133
Shipping Classification	UN 3480, CLASS 9

ULTIMATRON FRANCE

Add: 286 Rue Charles Gide, 34670 Baillargues, France

✉ info@ultimatron-france.fr

☎ Tel:+33(0)9 50 42 76 17

