

Technical sheet

ULTMATRON LiFePO4 Smart BMS RV Underseat Lithium Battery
ULM-12-280H (with Heater)



Note: It can be connected in parallel within 4 pcs. Series connection is not allowed.

Integrated Battery Management System (BMS)

To allow the control and the charge of the different elements of an accumulator battery and to protect it against overcharging, overvoltages and overheating.



Heating Features

- ★ The integrated heating function starts automatically at temperatures below 0°C when an external charging current (around 7A) is applied. The integrated heating function will not consume the energy from the battery.
- ★ Integrated Heating foils, the battery can be charged at the extreme environment in **-35°C**.

Compared with traditional batteries, our lithium iron phosphate batteries (LiFePO4) have many advantages:

- 5 years manufacturer's warranty
- The safest technology, without risk of fire or explosion
- Long service life
- Constantly improving storage capacity
- High stability even under extreme loads
- No memory effect, no need for full charge and discharge cycles
- High performance even under extreme conditions
- Deep and regular discharge and charging efficiency

Integrated Bluetooth 4.0 monitoring



You have all important battery data always on your smartphone or tablet. The application displays the data in real time.





ULTIMATRON LiFePO4 Smart BMS RV Underseat Lithium Battery ULM-12-280H (with Heater)

ELECTRICAL PERFORMANCE

Nominal Voltage	12.8V
Nominal Capacity	280Ah
Capacity @ 36A	336min
Energy	3584Wh
Resistance	≤15 mΩ @ 50% SOC
Self Discharge	<3% / Month
Number of Cycles	>6000@80%D.o.D

CHARGE PERFORMANCE

Recommended Charge Current	80A
Maximum Charge Current	140A
Recommended Charge Voltage	14.6V
Charge Cut-Off Voltage	14.6V (2000ms)
Reconnect Voltage	≤13.8V
Balancing Voltage	>12.8V

DISCHARGE PERFORMANCE

Maximum continuous Discharge Current	200A
Peak Discharge Cut-Off Current	600A (200~500ms)
Discharge Cut-Off Voltage	10V (2000 ms)
Reconnect Voltage	>11.2V
Short Circuit Protection	1000-2000A ± 400A (200 ~ 800 μs)

TEMPERATURE PERFORMANCE

Discharge Temperature	-20 ~ 75 °C
Charge Temperature	0 ~ 50 °C ❄️
Heater Working Temperature	-35 ~ 5 °C ❄️
Storage Temperature	-5 ~ 35 °C

DIMENSION

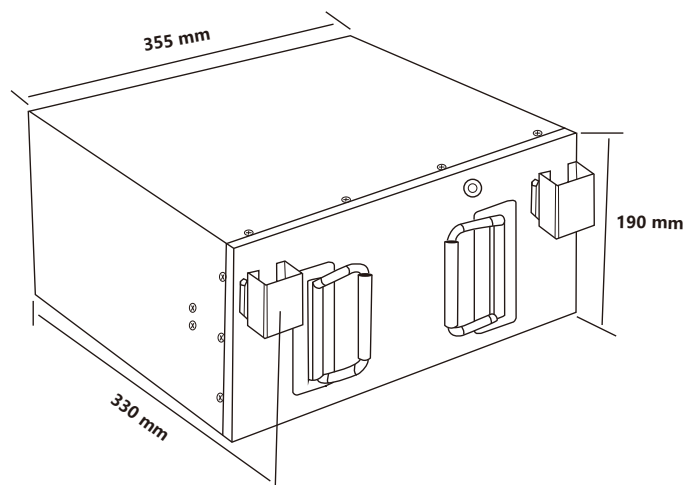

Dimension	L355 * W330 * H190 mm
-----------	-----------------------

MECHANICAL PERFORMANCE

Weight	31kg
Terminal Type	M8
Terminal Torque	80 ~ 100 in-lbs (9 ~ 11 N-m)
Case Material	Metal
Ingress Protection Code	IP65
Bluetooth	Bluetooth 4.0 with smartphone App
Heat foil	80W

COMPLIANCE

Certifications	CE UN38.3 UL1642 & IEC62133
Shipping Classification	UN 3480, CLASS 9